



DESCRIPTION

PT2387 is a 3D Effect Audio Processor IC utilizing CMOS Technology. It features a specially designed PTC HRTFs Filter and space-enhanced circuit, thereby, guaranteeing excellent audio quality and performance. Least external components, excellent 3D effect audio output, built-in LED display driver add to the enhanced quality of PT2387. Pin assignments and application circuit are optimized for easy PCB Layout and cost saving benefits.

FEATURES

- CMOS technology
- Operating voltage range: 5V to 9 V
- THD=N<0.01%, S/N>95dB
- Specially designed PTC HRTFs filter technology and 3D space-enhanced circuit
- Least external components
- Built-in LED display driver
- Available in 8 Pins, DIP or SOP

APPLICATIONS

- Multi-media audio
- Car audio
- Walkman
- Home stereo
- TV
- PC speakers
- Notebook Computer/Laptop
- Other audio equipment



BLOCK DIAGRAM

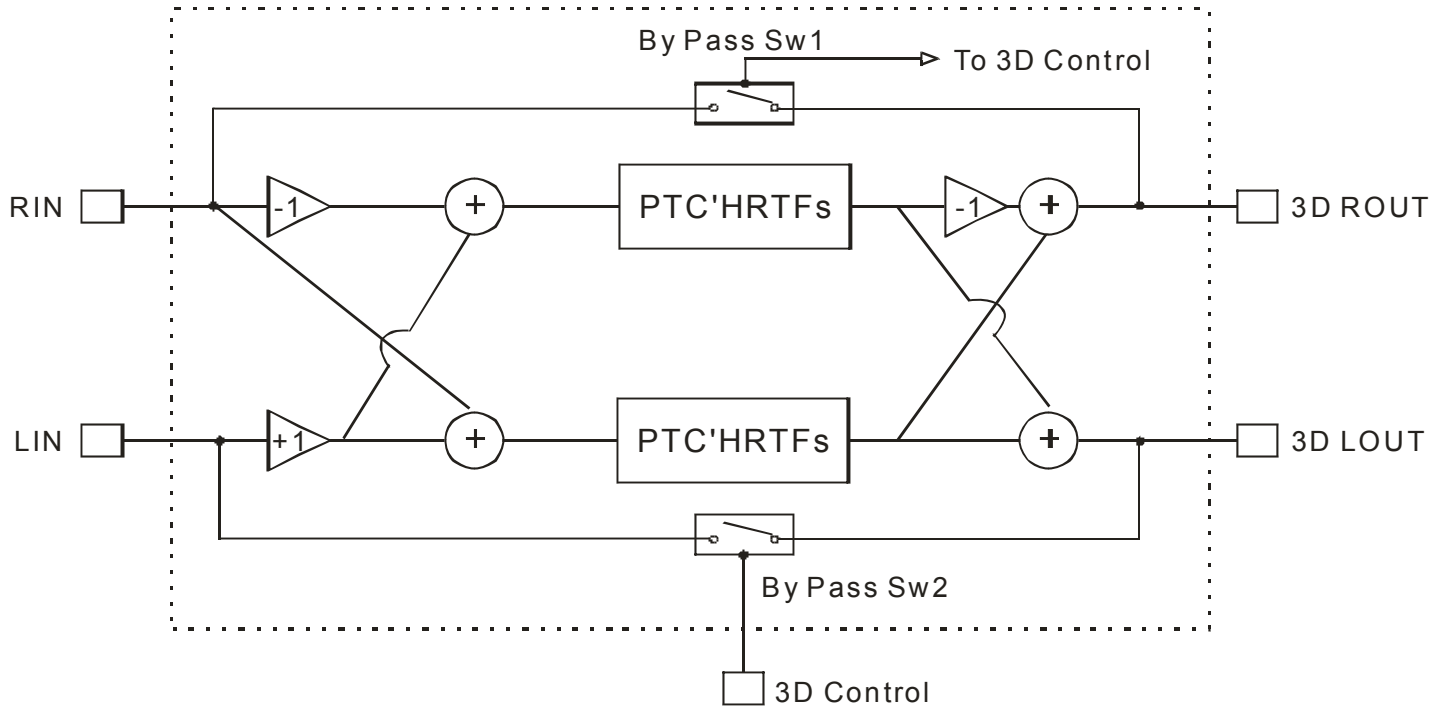



PIN CONFIGURATION

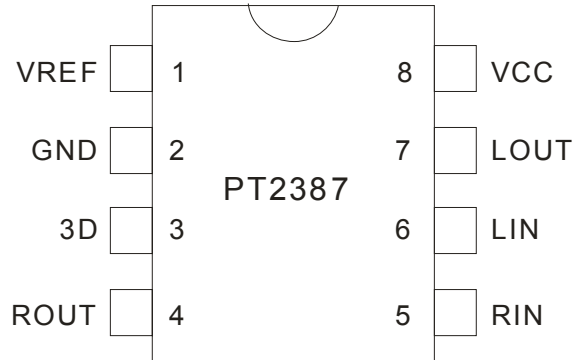

PIN DESCRIPTION

| Pin Name | I/O | Description | Pin No. |
|----------|-----|-------------------------------------|---------|
| VREF | O | 1/2 VCC Connect capacitor to GND | 1 |
| GND | - | Ground Pin | 2 |
| 3D | I | 3D Effect Control Pin | 3 |
| ROUT | O | Right Channel Output Pin | 4 |
| RIN | I | Right Channel Input Pin | 5 |
| LIN | I | Left Channel Input Pin | 6 |
| LOUT | O | Left Channel Output Pin | 7 |
| VCC | - | Positive Power Supply | 8 |



FUNCTION DESCRIPTION

The 3D effect of PT2387 is controlled by Pin No.3 (3D pin) via a TACT Switch which is triggered when connected to Vcc ("High"). Please refer to the diagram below.

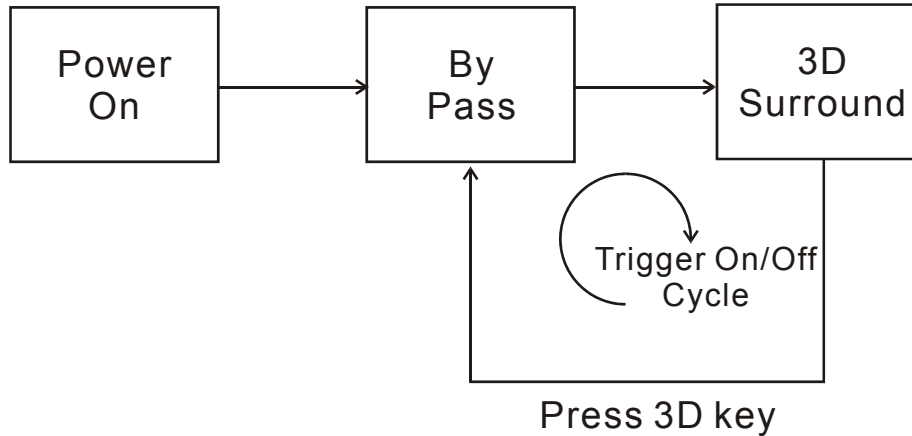

LED DISPLAY DRIVER

PT2387 has a built-in LED driver which is used to display the 3D activity status. Please refer to the table below.

| 3D/Surround Effect OFF | 3D/Surround Effect ON |
|------------------------|-----------------------|
| LED Display OFF | LED Display ON |



ABSOLUTE MAXIMUM RATING

| Parameter | Symbol | Ratings | Unit |
|-----------------------|-----------|---------------------|------|
| Positive power supply | V_{CC} | 12 | V |
| Input voltage | V_i | 0.3 to $V_{CC}+0.3$ | V |
| Operating temperature | T_{opr} | -40 ~ +85 | °C |
| Storage temperature | T_{stg} | -65 ~ +150 | °C |

DC ELECTRICAL CHARACTERISTICS

(Unless otherwise specified, $V_{CC}=9V$, $V_i=1V_{rms}$, $f=1KHz$, $T_a=27^{\circ}C$)

| Parameter | Symbol | Condition | Min. | Typ. | Max. | Unit |
|---------------------------|------------|---|-------------|------|-------------|------------|
| Operating voltage | V_{CC} | | 5 | 9 | 10 | V |
| Operating current | I_{CC} | $V_{CC}=9V$, $V_i=0V$, Bypass Mode | - | 20 | - | mA |
| Maximum output voltage | V_{OM} | $V_{CC}=9V$ | - | - | 2.5 | Vrms |
| Output noise voltage | V_{ON} | $V_{CC}=9V$, $V_i=0V$, BW=20 to 20KHz, A-weighting | - | -90 | - | dB |
| Total harmonic distortion | THD | $V_{CC}=9V$, $V_i=0.2V_{rms}$, BW=20 to 20KHz, Bypass Mode | - | - | 0.05 | % |
| Input impedance | R_{IN} | $V_{CC}=9V$ | - | 100 | - | K Ω |
| Output impedance | R_{OUT} | $V_{CC}=9V$ | - | 40 | 80 | Ω |
| High level input voltage | V_{IN} | $V_{CC}=9V$ | - | - | $0.7V_{CC}$ | V |
| Low level input voltage | V_{IL} | $V_{CC}=9V$ | $0.3V_{CC}$ | - | - | V |
| Maximum input voltage | V_{IMAX} | $V_{CC}=9V$, Bypass Mode | - | - | 2.0 | Vrms |



APPLICATION CIRCUIT

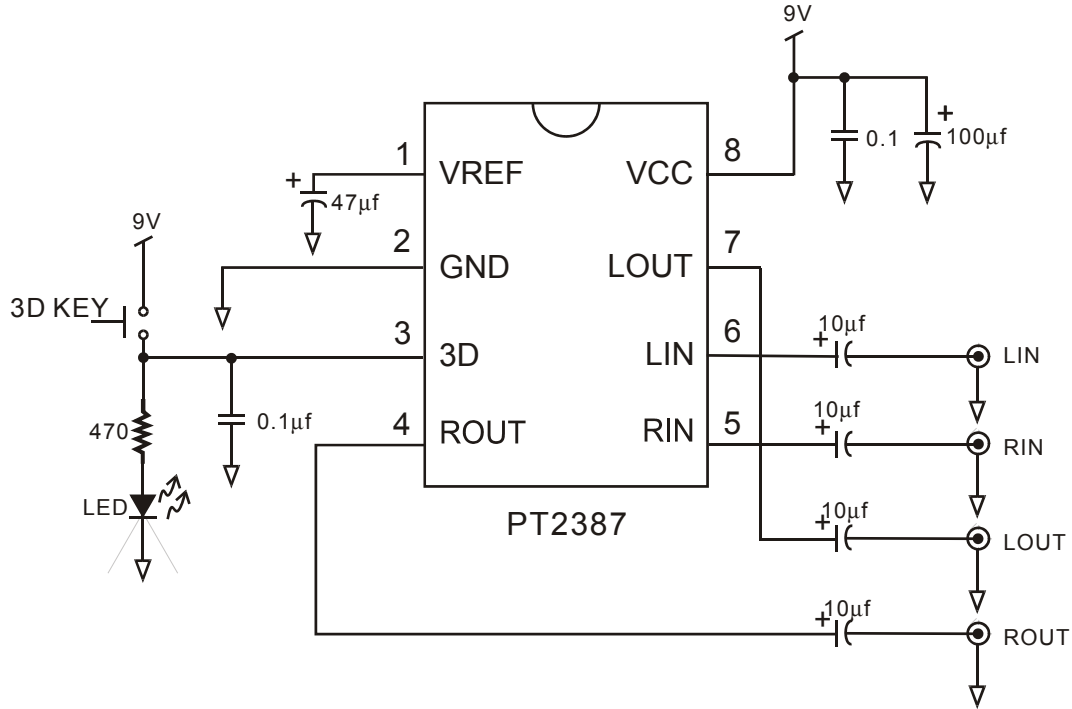



ORDER INFORMATION

| Valid Part Number | Package Type | Top Code |
|-------------------|---------------------|----------|
| PT2387 | 8 Pins, DIP, 300mil | PT2387 |
| PT2387-S | 8 Pins, SOP, 150mil | PT2387-S |



PACKAGE INFORMATION

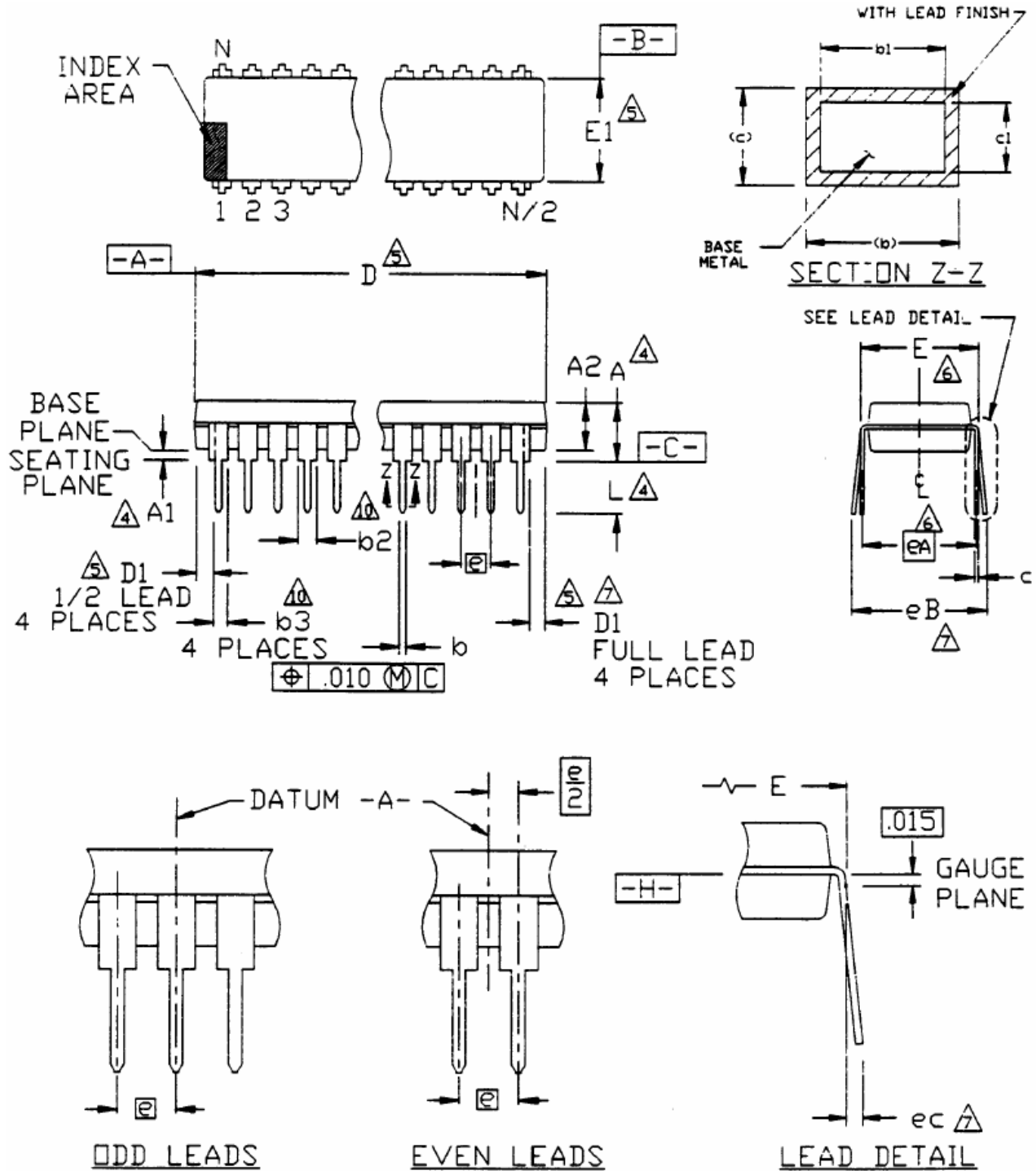

8 PINS, DIP, 300MIL





| Symbol | Min. | Nom. | Max. |
|--------|------------|-------|-------|
| A | - | - | 0.210 |
| A1 | 0.015 | - | - |
| A2 | 0.115 | 0.130 | 0.195 |
| b | 0.014 | 0.018 | 0.022 |
| b1 | 0.014 | 0.018 | 0.020 |
| b2 | 0.045 | 0.060 | 0.070 |
| b3 | 0.030 | 0.039 | 0.045 |
| c | 0.008 | 0.010 | 0.014 |
| c1 | 0.008 | 0.010 | 0.011 |
| D | 0.355 | 0.365 | 0.400 |
| D1 | 0.005 | - | |
| E | 0.300 | 0.310 | 0.325 |
| E1 | 0.240 | 0.250 | 0.280 |
| e | 0.100 bsc. | | |
| eA | 0.300 bsc. | | |
| eB | - | - | 0.430 |
| eC | 0.000 | - | 0.060 |
| L | 0.115 | 0.130 | 0.150 |

Notes:

- Controlling Dimensions: INCHES.
- Dimensioning and tolerancing per ANSI Y14.5M-1982.
- Symbols are defined in the "MO Series Symbol LIST" in Section 2.2 of Publication No.95.
- Dimension A, A1 and L are measured with the package seated in JEDEC Seating Plane Gauge GS-3.
- D, D1 and E1 dimensions do not include mold flash or protrusions. Mold flash or protrusions shall not exceed 0.010 inch.
- E and eA measured with the leads constrained to be perpendicular to data .
- eB and eC are measured at the lead tips with the leads unconstrained.
- N is the number of leads (N=8)
- Pointed or rounded lead tips are preferred to ease insertion.
- b2 and b3 maximum dimensions do not include dambar protrusions. Dambar protrusions shall not exceed 0.010 inch (0.25mm)
- Variation BA has a b3 dimension and is 1/2 lead package.
- Distance between the leads including dambar protrusions to be 0.005 inch minimum.
- Datum plane  coincident with the bottom of lead, where lead exits the body.
- Refer to JEDEC MS-001, Variation BA.

JEDEC is the registered trademark of JEDEC SOLID STATE TECHNOLOGY ASSOCIATION.



3D Effect Audio Processor IC

PT2387

8 PINS, SOP, 150MIL

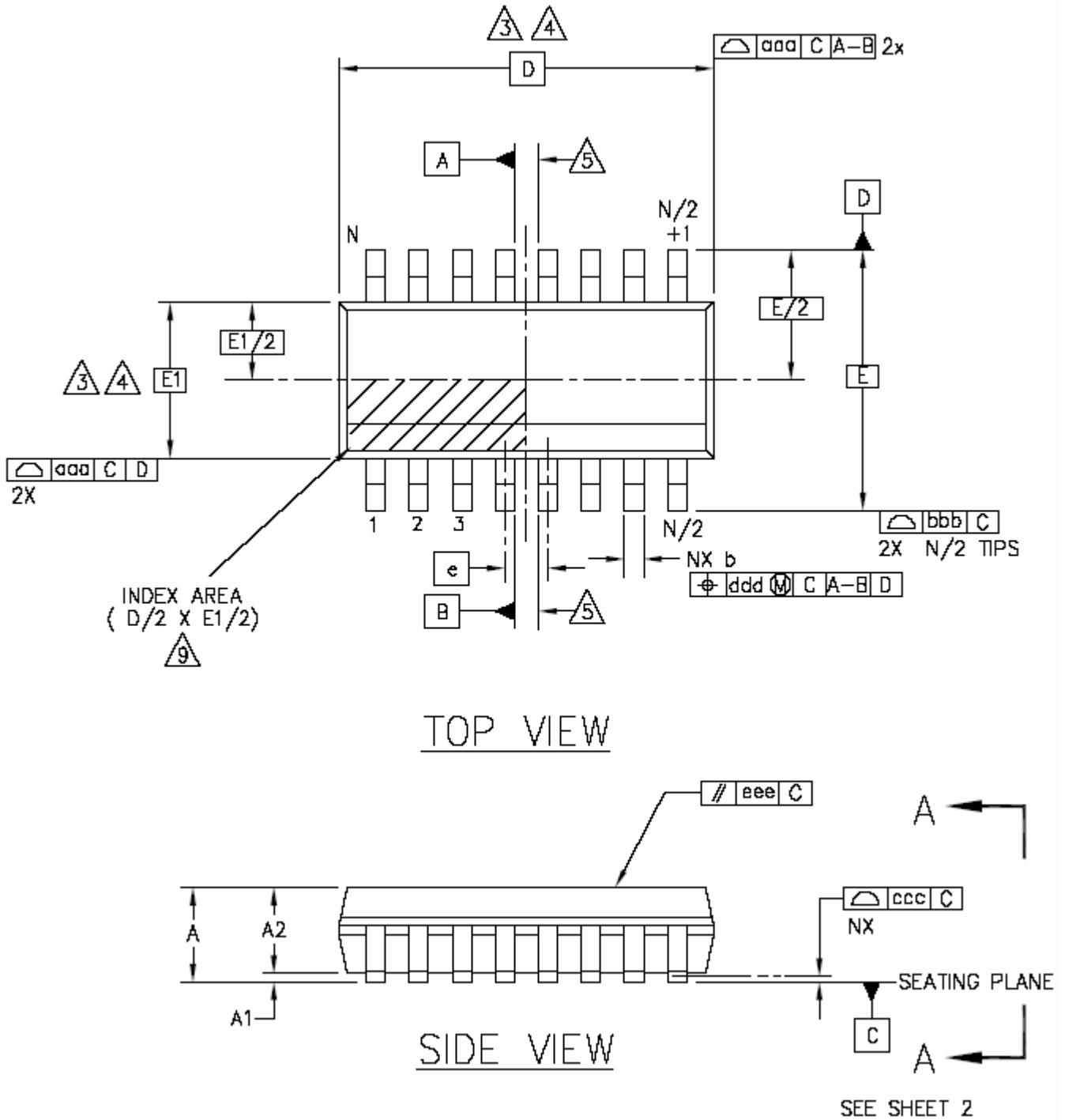



3D Effect Audio Processor IC

PT2387

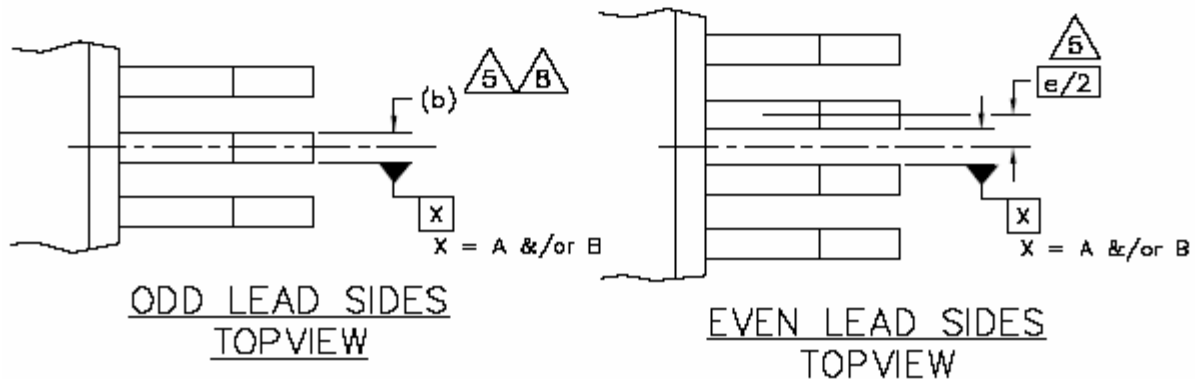
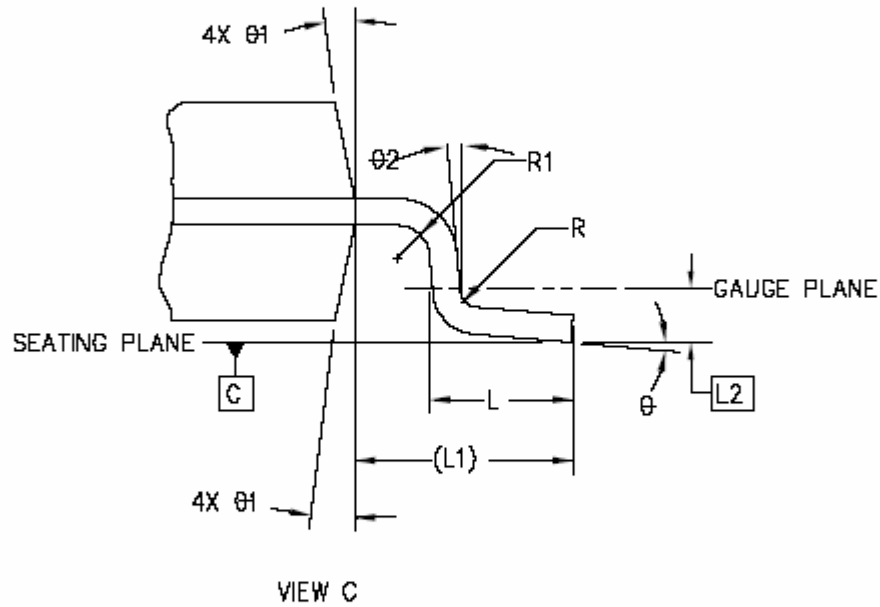
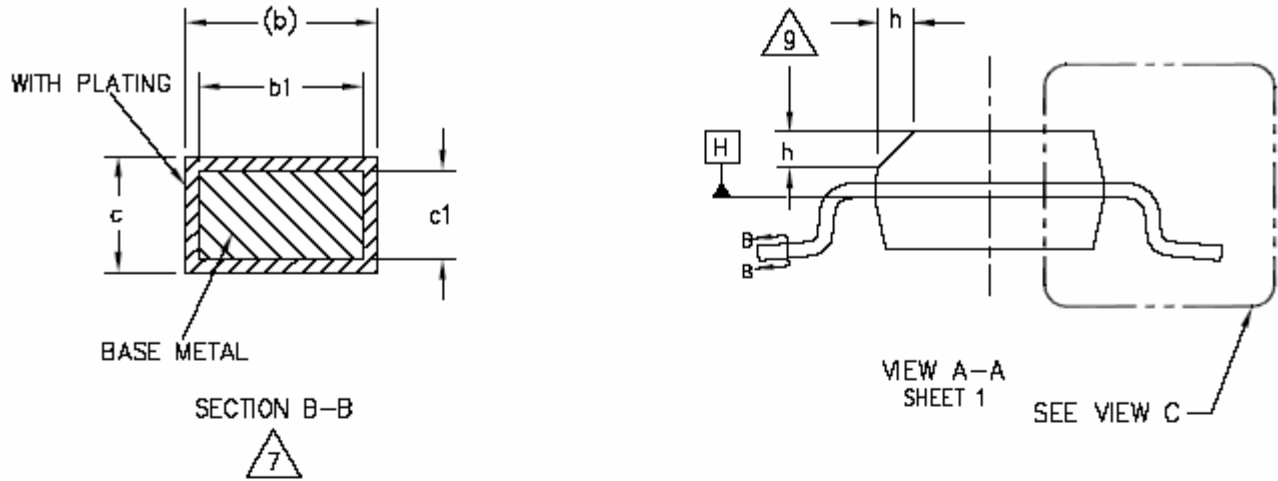



3D Effect Audio Processor IC

PT2387

| Symbol | Min. | Typ. | Max. |
|------------|-----------|------|------|
| A | 1.35 | - | 1.75 |
| A1 | 0.10 | - | 0.25 |
| A2 | 1.25 | - | 1.65 |
| b | 0.31 | - | 0.51 |
| b1 | 0.28 | - | 0.48 |
| c | 0.17 | - | 0.25 |
| c1 | 0.17 | - | 0.23 |
| D | 4.90 BSC. | | |
| E | 6.00 BSC. | | |
| E1 | 3.90 BSC. | | |
| e | 1.27 BSC. | | |
| L | 0.40 | - | 1.27 |
| L1 | 1.04 REF. | | |
| L2 | 0.25 BSC. | | |
| R | 0.07 | - | - |
| R1 | 0.07 | - | - |
| h | 0.25 | - | 0.50 |
| θ | 0° | - | 8° |
| $\theta 1$ | 5° | - | 15° |
| $\theta 2$ | 0° | - | - |

Notes:

1. Dimensioning and tolerancing per ANSI Y 14.5M-1994
2. Controlling Dimension: MILLIMETERS.
3. Dimension D does not include mold flash protrusions or gate burrs. Mold flash, protrusions or gate burrs shall not exceed 0.15 mm (0.006 in) per end. Dimension E1 does not include interlead flash or protrusion. Interlead flash or protrusion shall not exceed 0.25mm per side. D and E1 dimensions are determined at datum H.
4. The package top may be smaller than the package bottom. Dimensions D and E1 are determined at the outermost extremes of the plastic body exclusive of mold flash, tie bar burrs, gate burrs and interlead flash, but including any mismatch between the top and bottom of the plastic body.
5. Datums A & B to be determined at datum H.
6. N is the number of terminal positions. (N=8)
7. The dimensions apply to the flat section of the lead between 0.10 to 0.25mm from the lead tip.
8. Dimension "b" does not include dambar protrusion. Allowable dambar protrusion shall be 0.10mm total in excess of the "b" dimension at maximum material condition. The dambar cannot be located on the lower radius of the foot.
9. This chamfer feature is optional. If it is not present, then a pin 1 identifier must be located within the index area indicated.
10. Refer to JEDEC MS-012, Variation AA.
JEDEC is the registered trademark of JEDEC SOLID STATE TECHNOLOGY ASSOCIATION.